

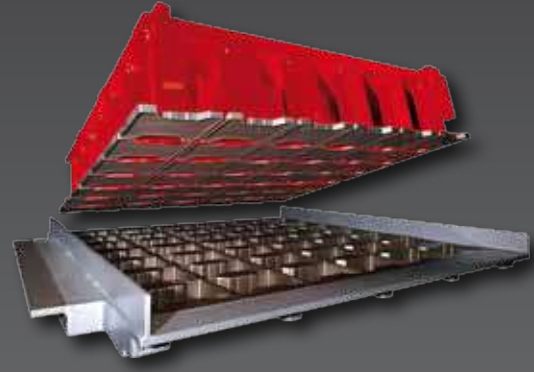

**PEGASO
STAMPI**

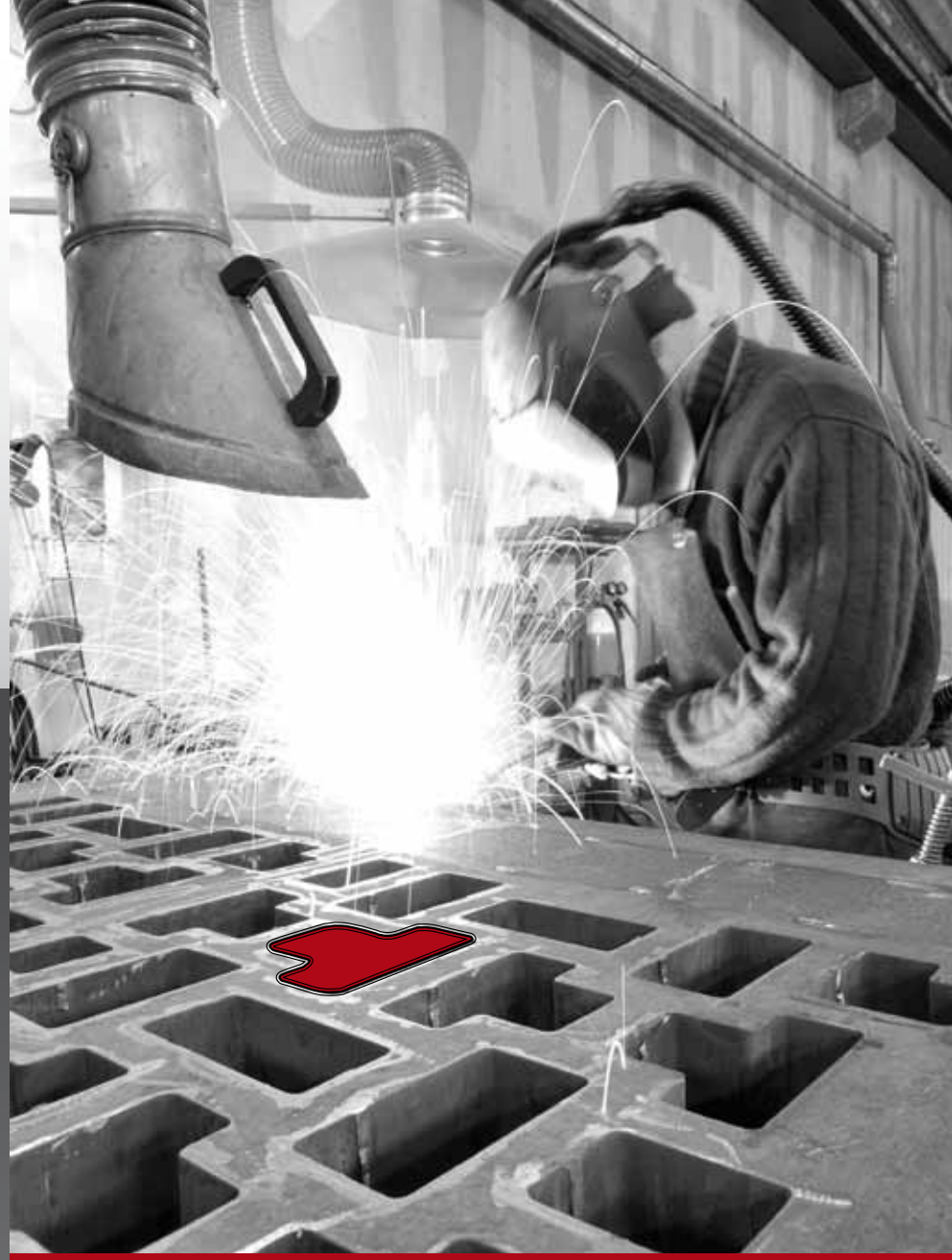

**DESIGN AND
PRODUCTION
OF MOULDS
FOR CONCRETE
ELEMENTS**

DESIGN AND PRODUCTION OF MOULDS FOR CONCRETE ELEMENTS

PEGASO STAMPI

moulds for paving stones, moulds for blocks and kerbs,
moulds for garden elements

After over 12 years in the business, Pegaso Stampi has established itself as a solid Italian company in the production of moulds for concrete elements.

By exploiting typical Italian inventiveness and creativity, Pegaso Stampi is proud of its production, sales and after-sales service and of the commercial relations it maintains with its customers.

PEGASO STAMPI

moldes para adoquines, moldes para bloques y bordillos,
moldes para bloques de césped

Tras más de 12 años de actividad, Pegaso Stampi se ha afirmado como una sólida realidad italiana en el campo de los moldes para piezas de hormigón.

Explotando la inventiva y la creatividad típicamente italiana, Pegaso Stampi está orgullosa de su propia producción, de su propio servicio pre- y post-venta y de las relaciones de colaboración que mantiene con sus clientes.

PEGASO STAMPI

moldes para pavimentação, moldes para blocos e lancis,
moldes para grelhas

Após mais de 12 anos de atividade, a Pegaso Stampi se consolidou como uma sólida realidade italiana no campo dos moldes para elementos em concreto.

Desfrutando a inventividade e a criatividade tipicamente italiana, a Pegaso Stampi está orgulhosa da própria produção, do próprio serviço de pré e pós-venda e das relações de colaboração que mantém os seus clientes.



MOULDS FOR PAVING STONES

Moldes para adoquines
Moldes para pavimentação

MOULDS FOR BLOCKS AND KERBS

Moldes para bloques y bordillos
Moldes para blocos e lancis

MOULDS FOR GARDEN ELEMENTS

Moldes para bloques de césped
Moldes para grelhas

MOULDS WITH DETACHABLE CORES

Moldes con núcleos desmontables
Moldes com almas desmontáveis

COMPLETELY DETACHABLE MOULDS

Moldes completamente desmontables
Moldes completamente desmontáveis

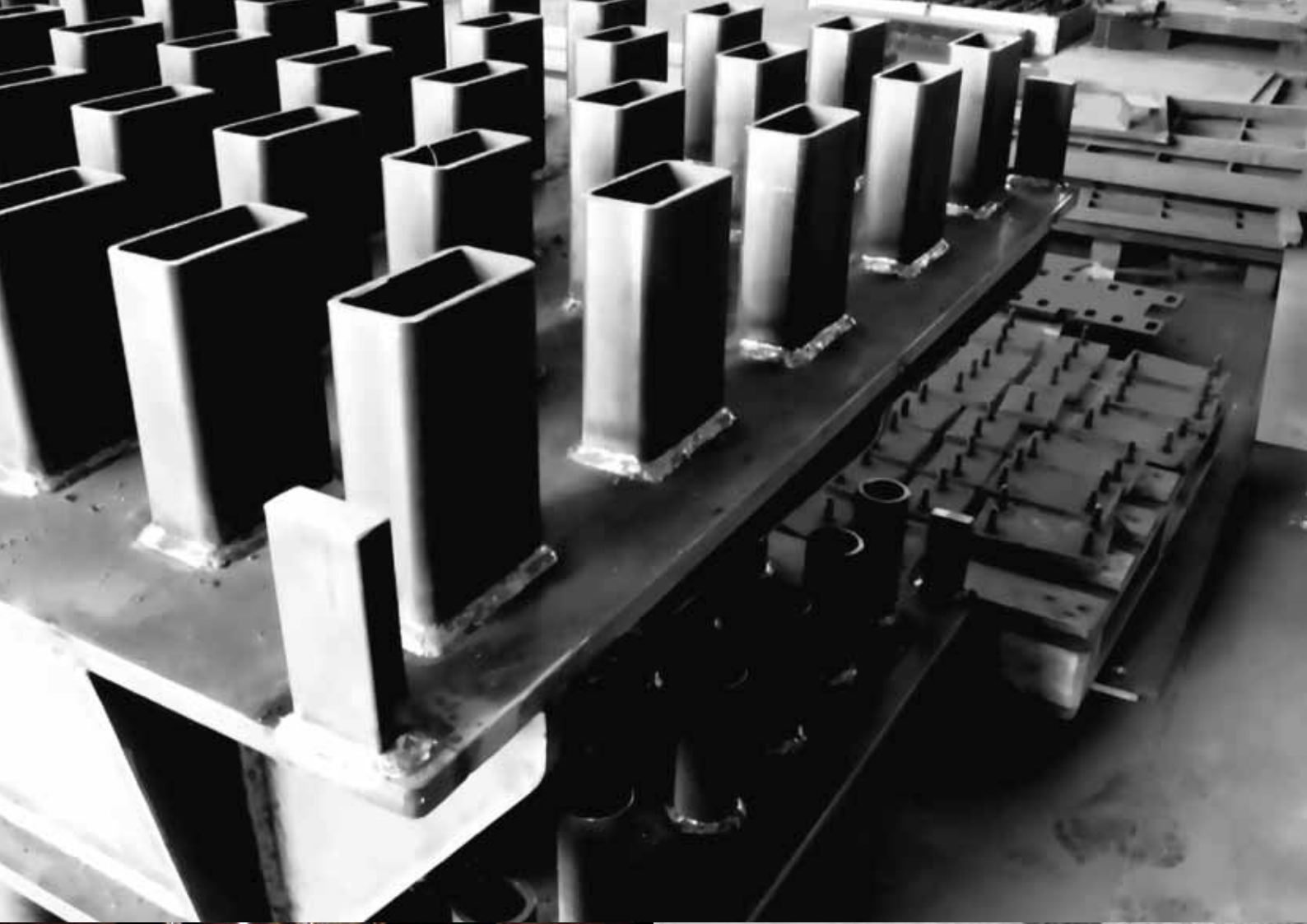



**PEGASO
STAMPI**

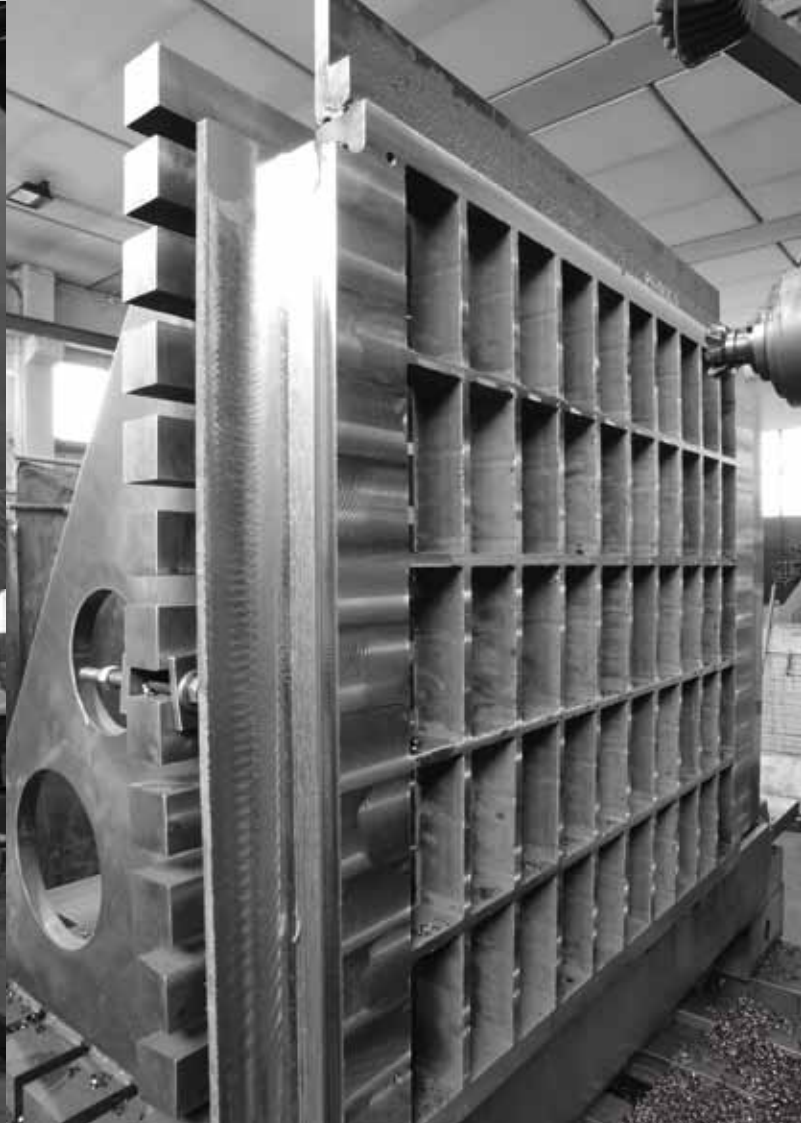

Moulds for paving stones

Made up of high tensile steel with high-hardened working surfaces, they assure a very long time of use. Cutting accuracy of the mould case and automatic adjustment of every single presser on each form, assure a constant and predefined clearance among all the pressers and the mould case.

The pressers are machined from the solid with the form united with the case, and then heat-treated and numbered one by one for a high accuracy level.



Moldes para adoquines

Fabricados en acero de alta resistencia con fuerte endurecimiento de las superficies de trabajo, garantizan una muy larga duración de uso.

La precisión de corte de la caja molde y el ajuste automático de cada prensador en cada perfil aseguran un juego constante y predefinido entre todos los prensadores y la caja molde.

Los prensadores se elaboran con una máquina a partir de material lleno con un perfil a juego con la caja, luego se tratan térmicamente y se enumeran uno a uno para obtener una precisión de alto nivel.

Moldes para pavimentação

Construídos com aço alto resistencial com forte endurecimento das superfícies de trabalho, garantem uma duração muito elevada.

A precisão do corte da caixa molde e o ajuste automático de cada amontoador sobre cada modelo garantem um jogo constante e pré-definido entre todos os prensadores e a caixa.

Os amontoadores são trabalhados por máquinas ferramentas cheios com perfil conjugado à caixa, logo são tratados termicamente e numerados um a um por uma precisão de alto nível.



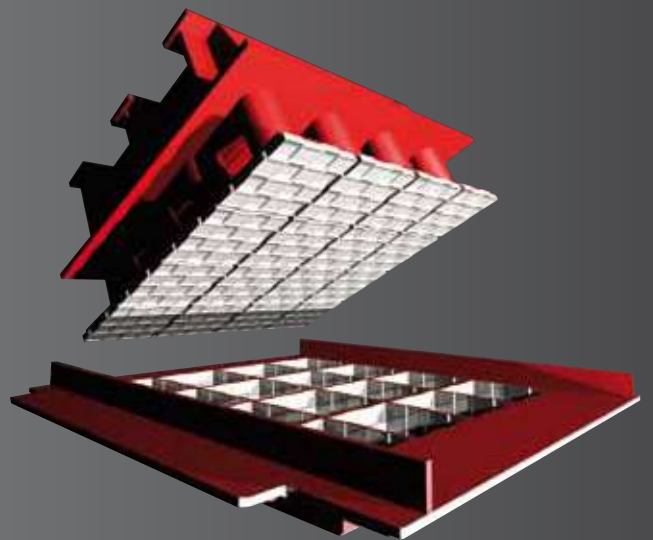
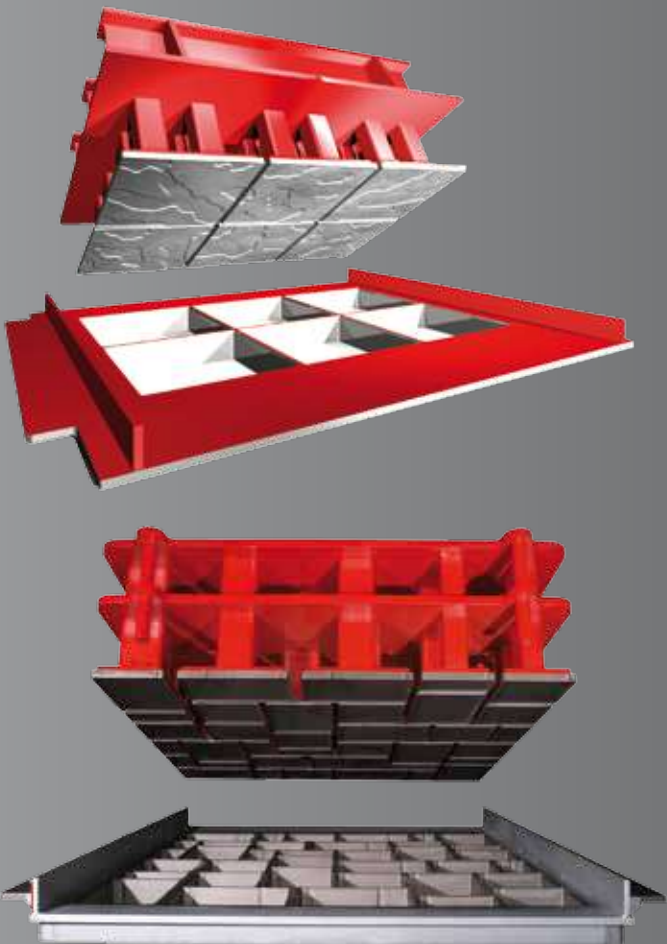
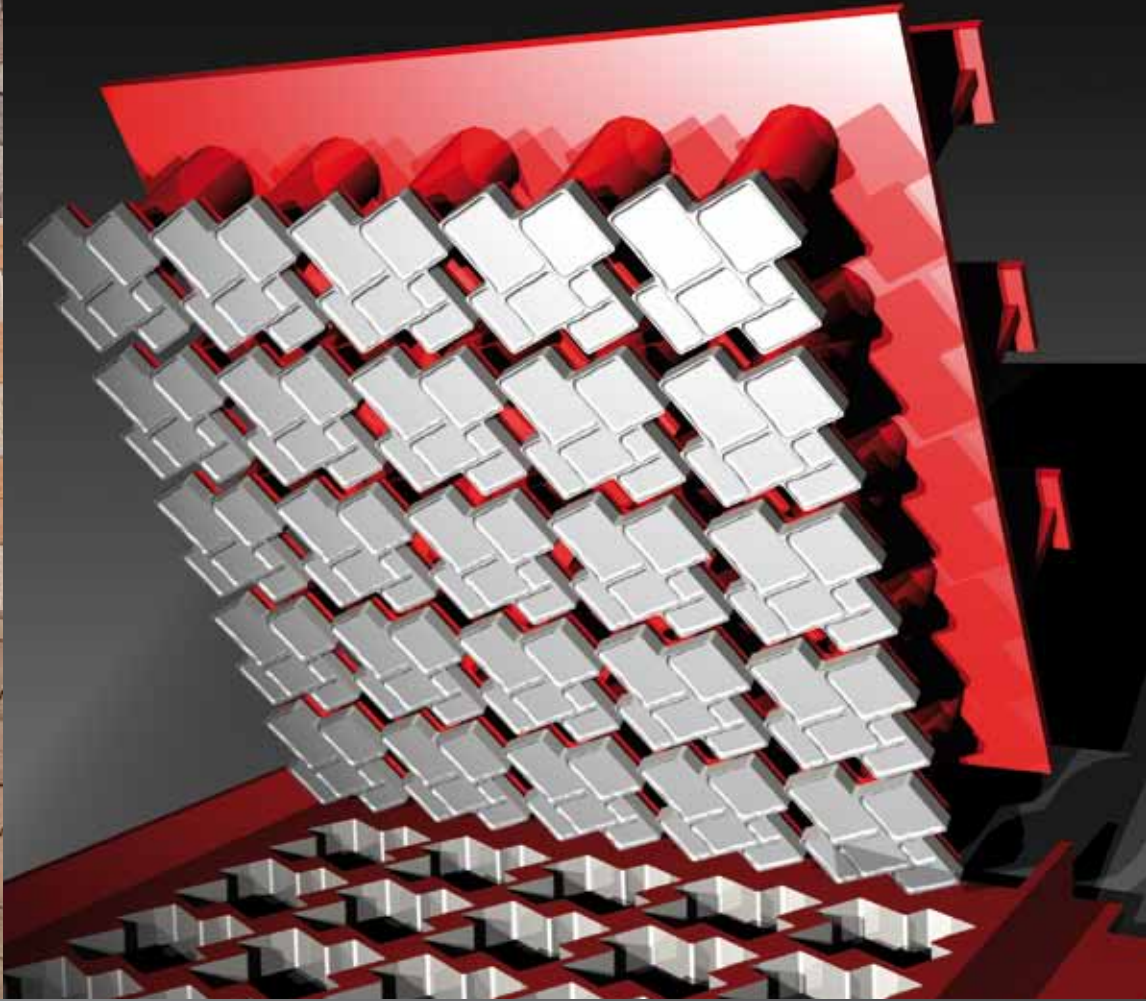

Moldes para
pavimentação

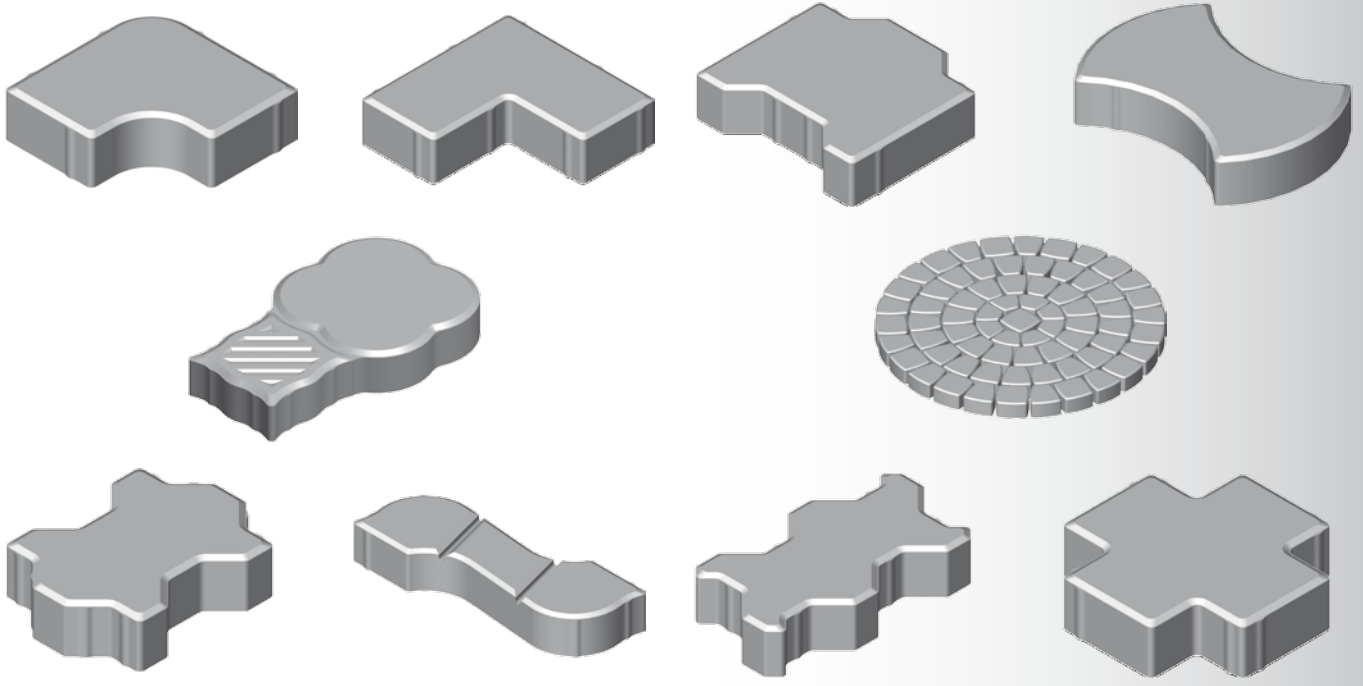

Moldes para
adoquines

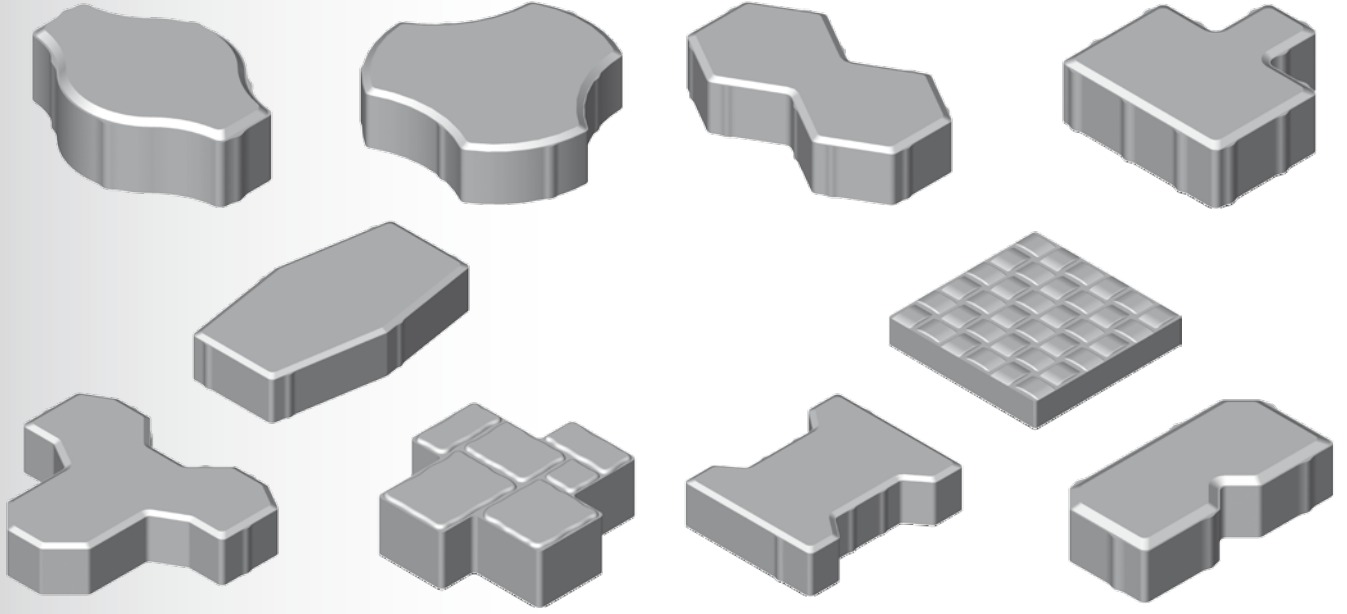

Moulds
for paving stones

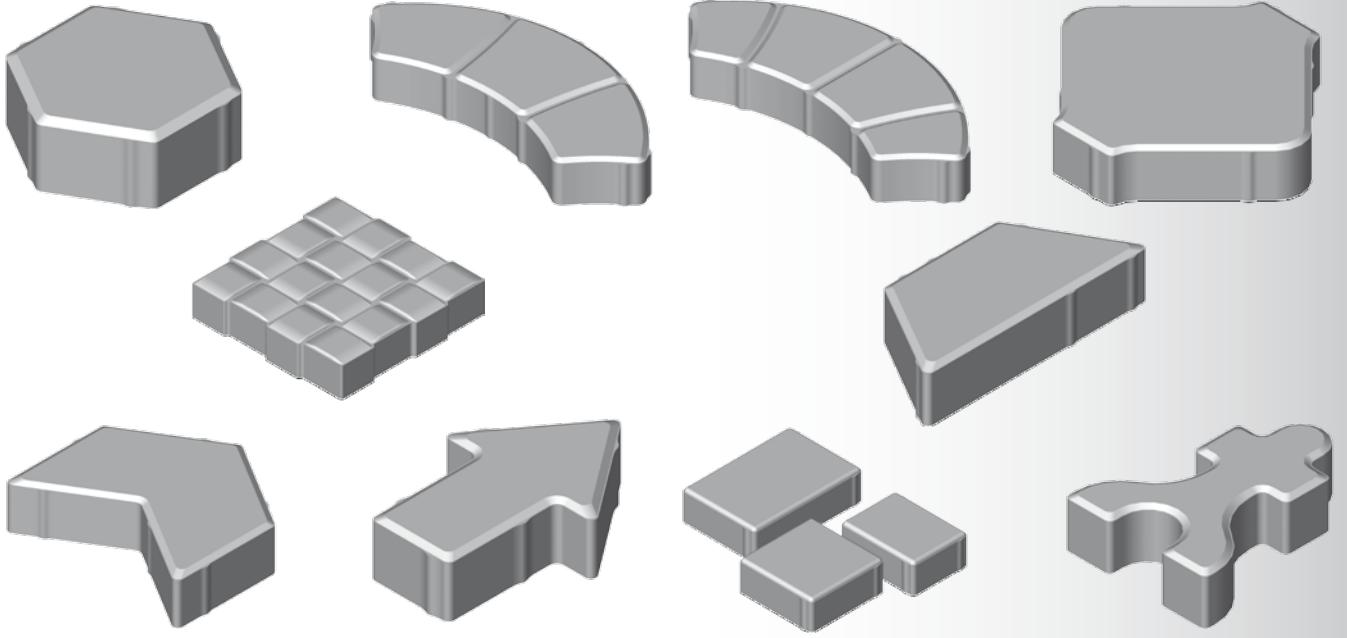

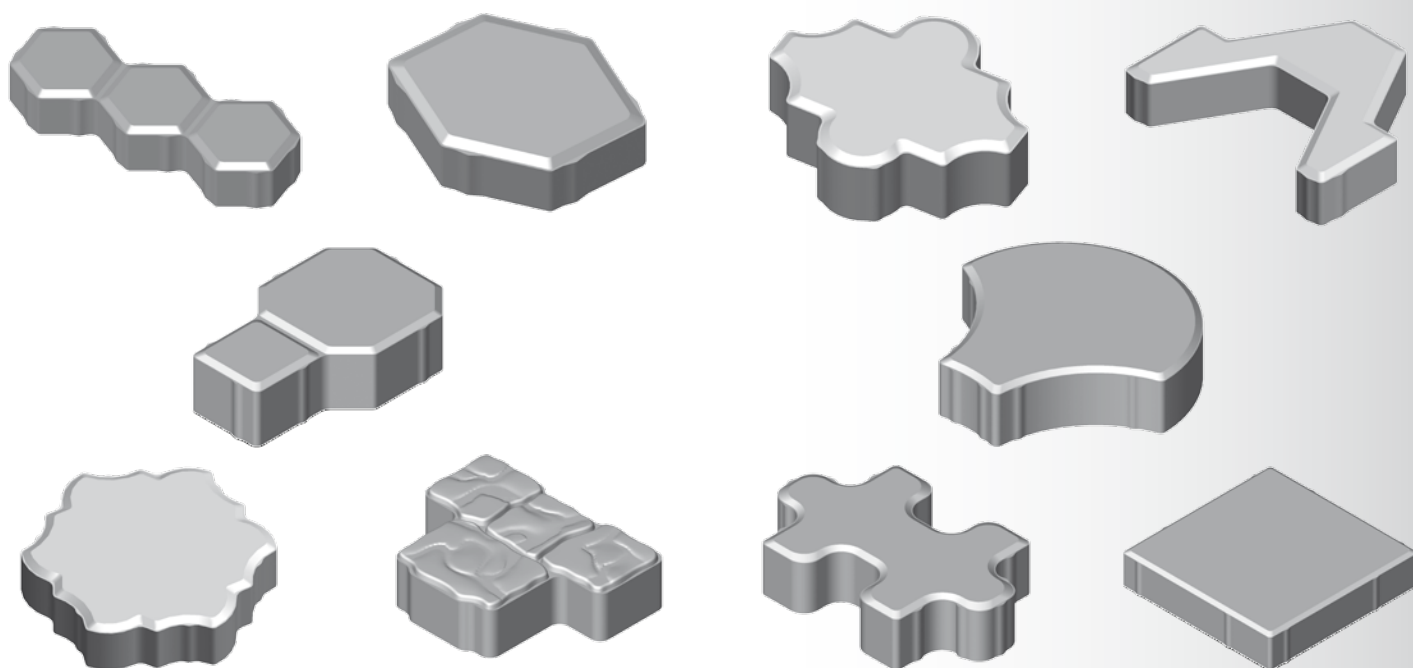
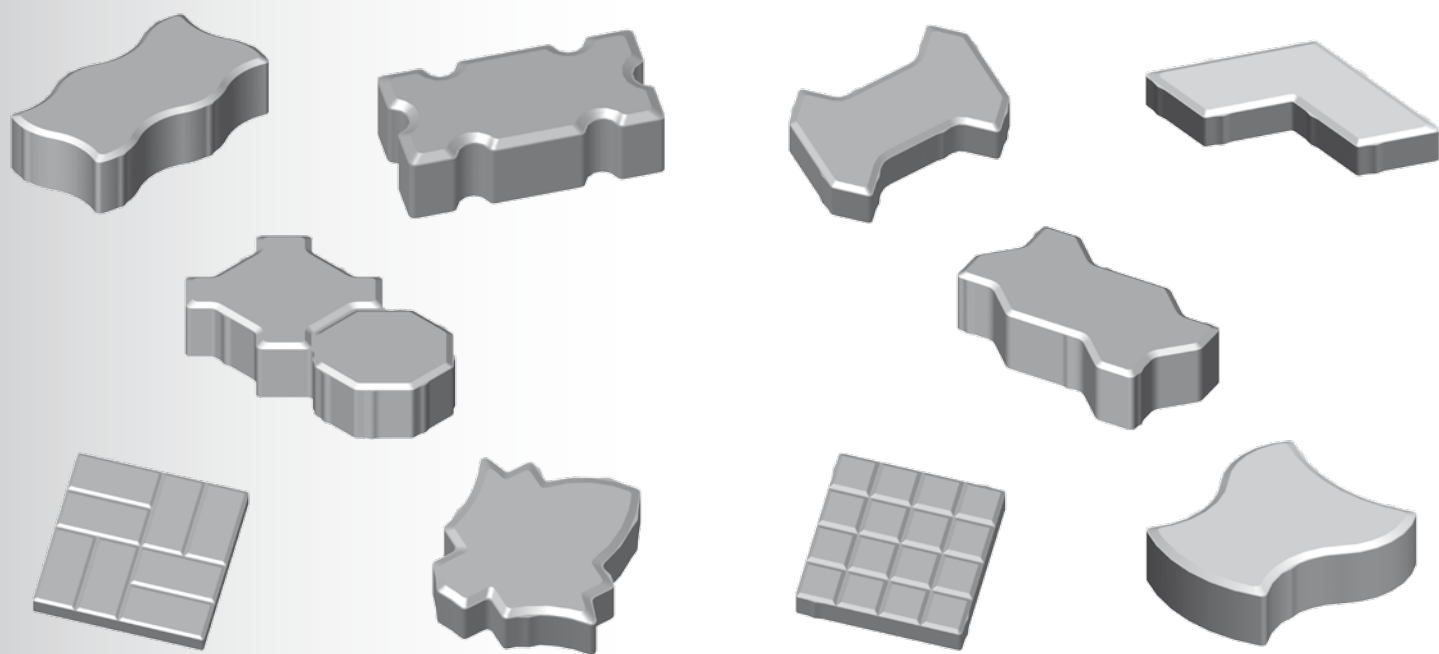
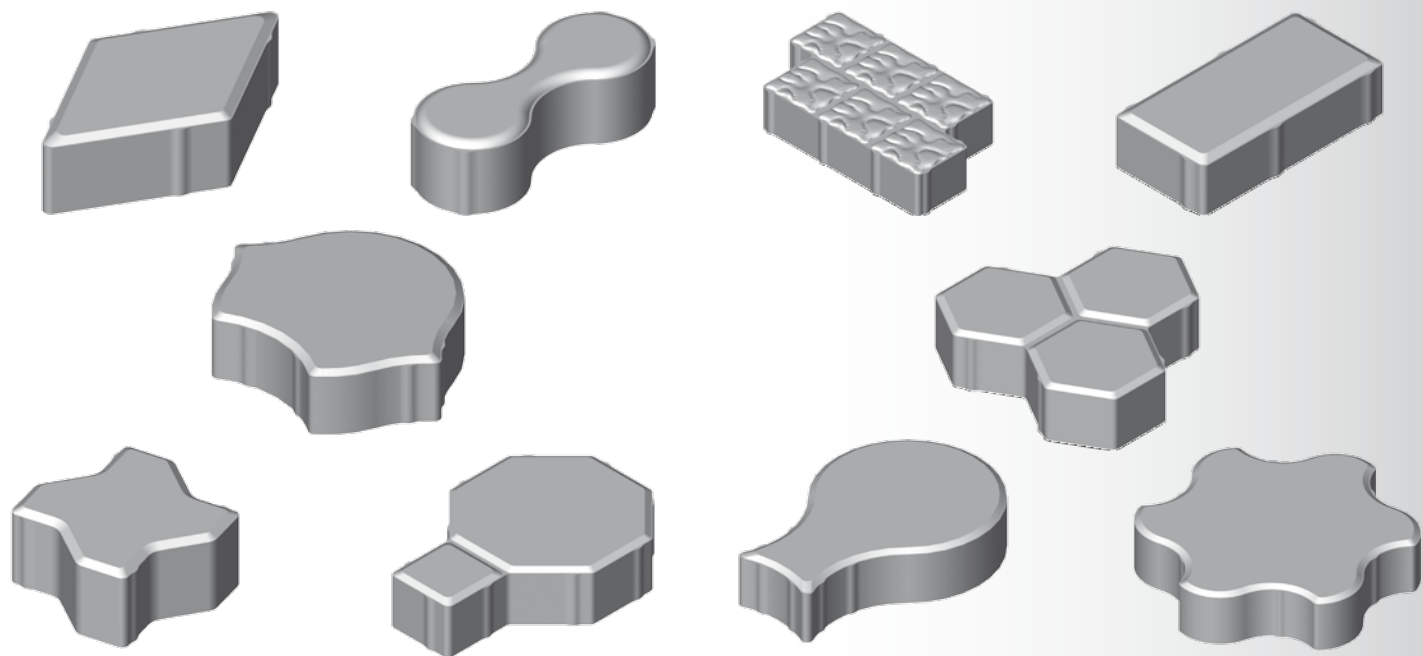

Moulds for blocks and kerbs

Made of special abrasion-resistant laser-sectioned steel, the moulds, featuring innovative assembly devices, are “hand-made” by experienced specialists. Endless research on materials and assembly methods provide sturdiness and accuracy results at the top of the state-of-the-art technology.

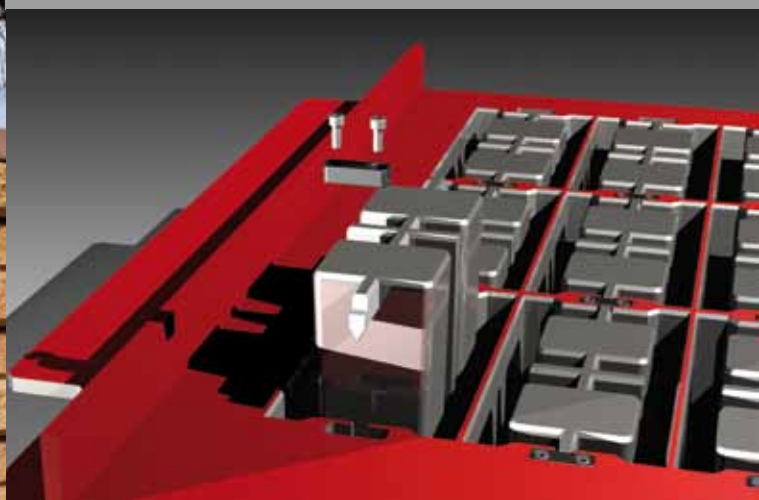

Moldes para bloques y bordillos

Fabricados con acero especial antiabrasión cortado con láser con innovadores dispositivos de ensamblaje, son productos “hechos a mano” por especialistas con gran experiencia. El estudio continuo de los materiales y de los métodos de ensamblaje ofrece resultados de robustez y precisión a la vanguardia.

Moldes para blocos e lancis

Construídos em aço especial antiabrasivo seccionado por laser com dispositivos de montagem inovadores, são produtos “feitos à mão” por especialistas com grande experiência. O estudo contínuo de materiais e metodologias de montagem permitem resultados de robustez e precisão nos vértices do estado da arte.



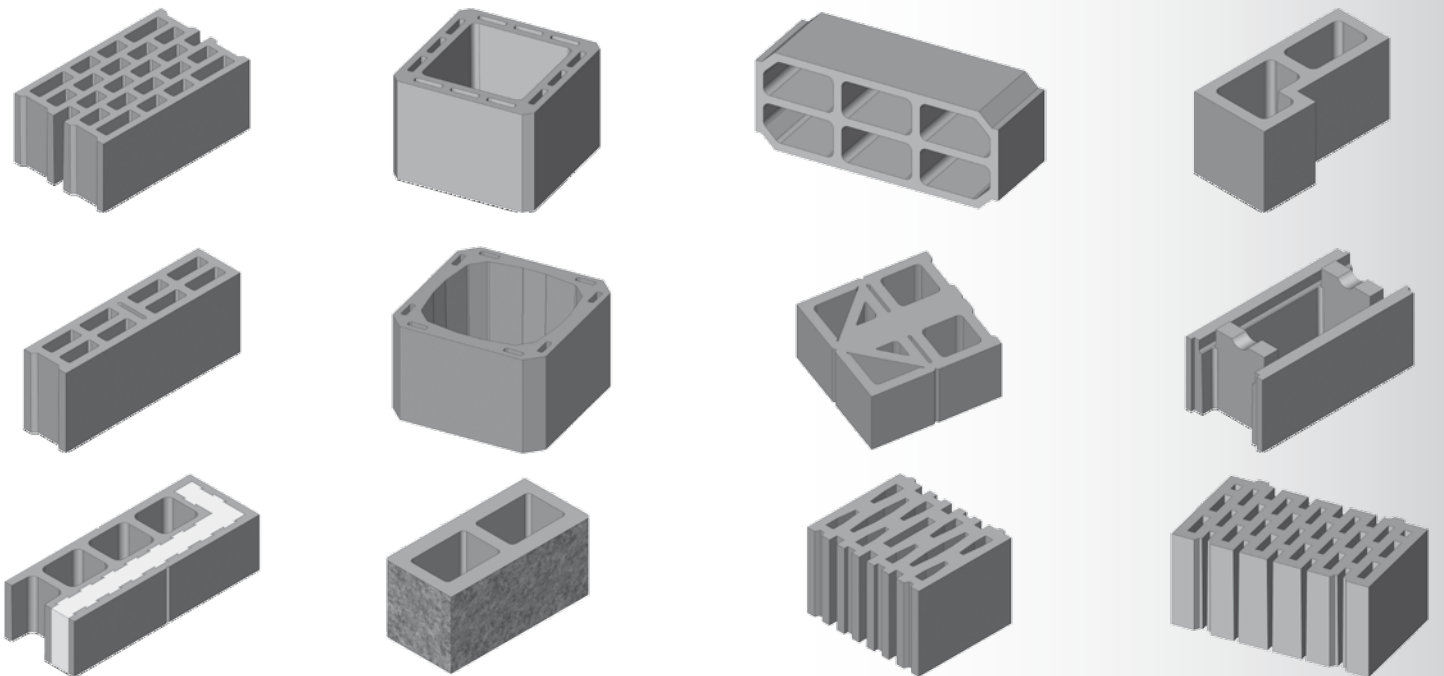
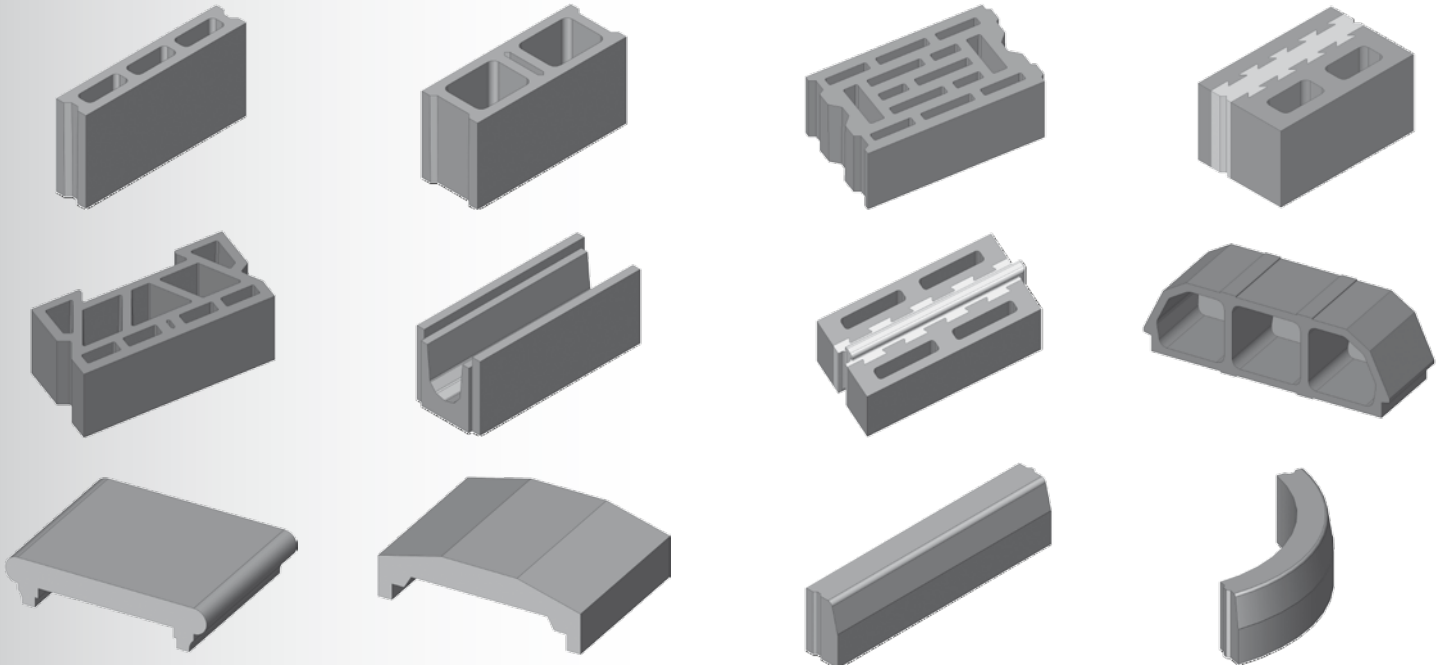
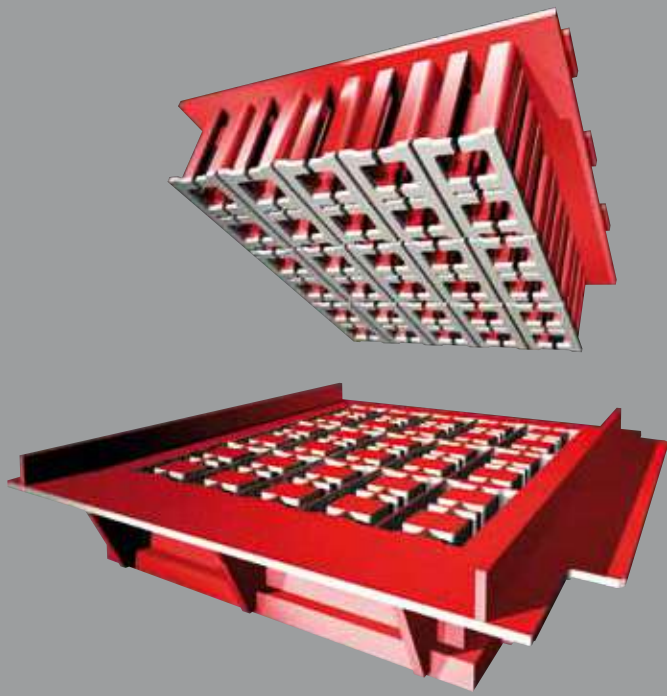

Moulds for garden elements

Made up of high tensile steel with high-hardened working surfaces, they assure a very long time of use. Cutting accuracy of the mould case and automatic adjustment of every single presser on each form, assure a constant and predefined clearance among all the pressers and the mould case.

The pressers are machined from the solid with the form united with the case, and then heat-treated and numbered one by one for a high accuracy level.



Moldes para bloques de césped

Fabricados en acero de alta resistencia con fuerte endurecimiento de las superficies de trabajo, garantizan una muy larga duración de uso.

La precisión de corte de la caja molde y el ajuste automático de cada prensador en cada perfil aseguran un juego constante y predefinido entre todos los prensadores y la caja molde.

Los prensadores se elaboran con una máquina a partir de material lleno con un perfil a juego con la caja, luego se tratan térmicamente y se enumeran uno a uno para obtener una precisión de alto nivel.

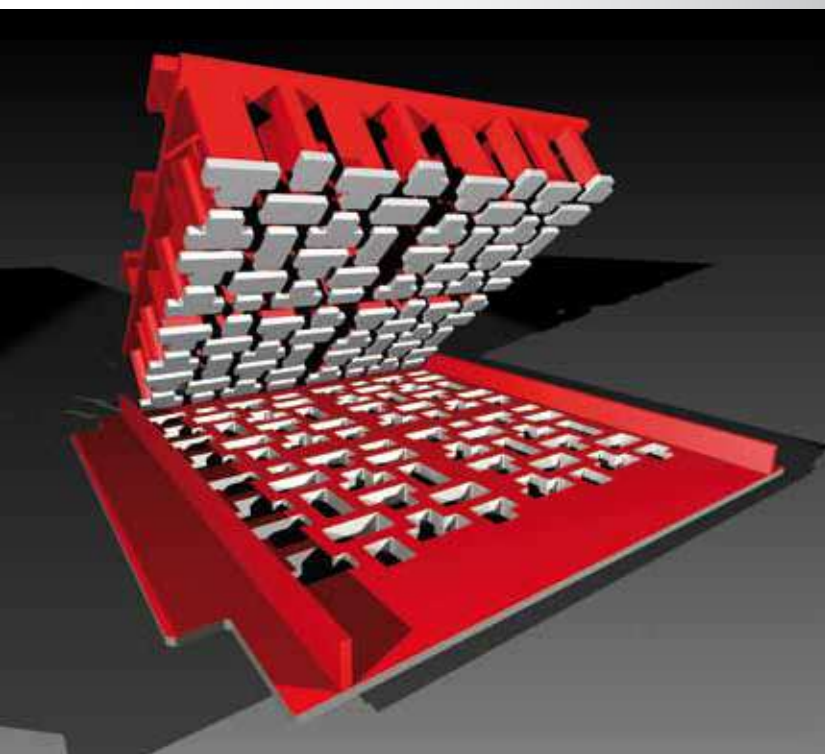

Moldes para grelhas

Construídos com aço alto resistencial com forte endurecimento das superfícies de trabalho, garantem uma duração muito elevada.

A precisão do corte da caixa molde e o ajuste automático de cada amontoador sobre cada modelo garantem um jogo constante e pré-definido entre todos os prensadores e a caixa.

Os amontoadores são trabalhados por máquinas ferramentas cheios com perfil conjugado à caixa, logo são tratados termicamente e numerados um a um por uma precisão de alto nível.



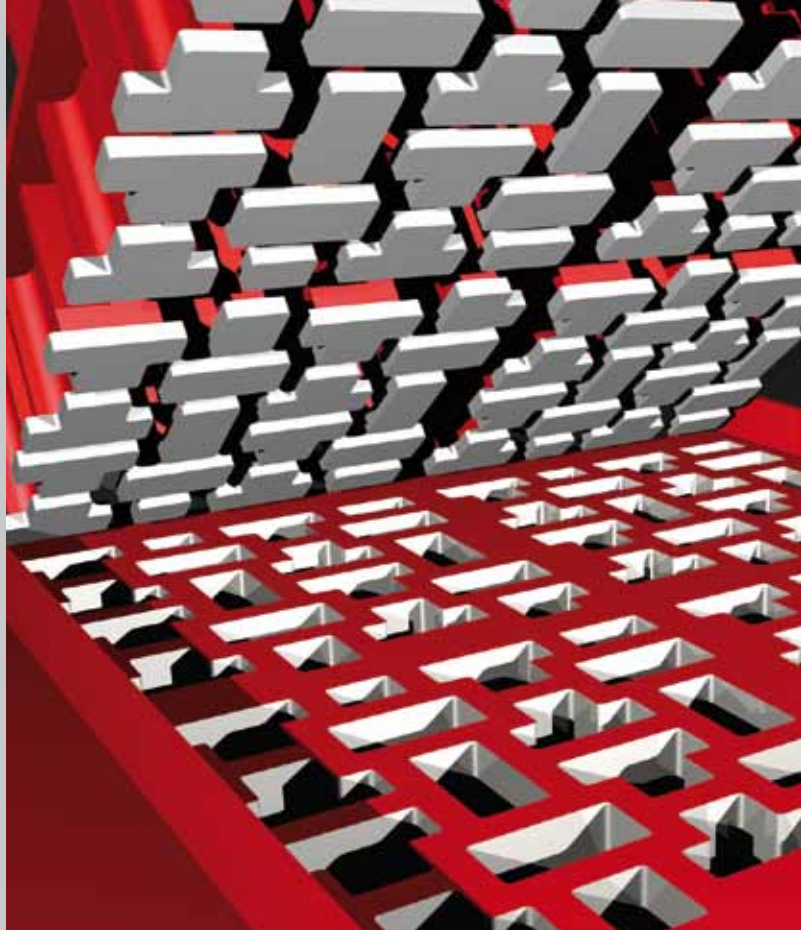
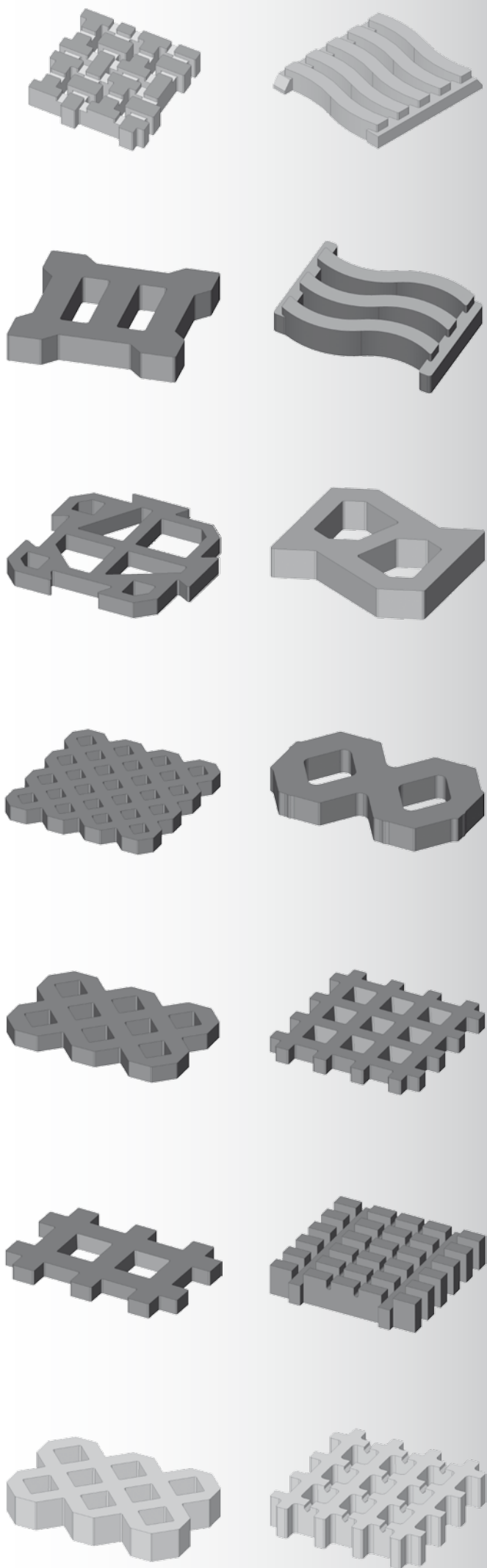

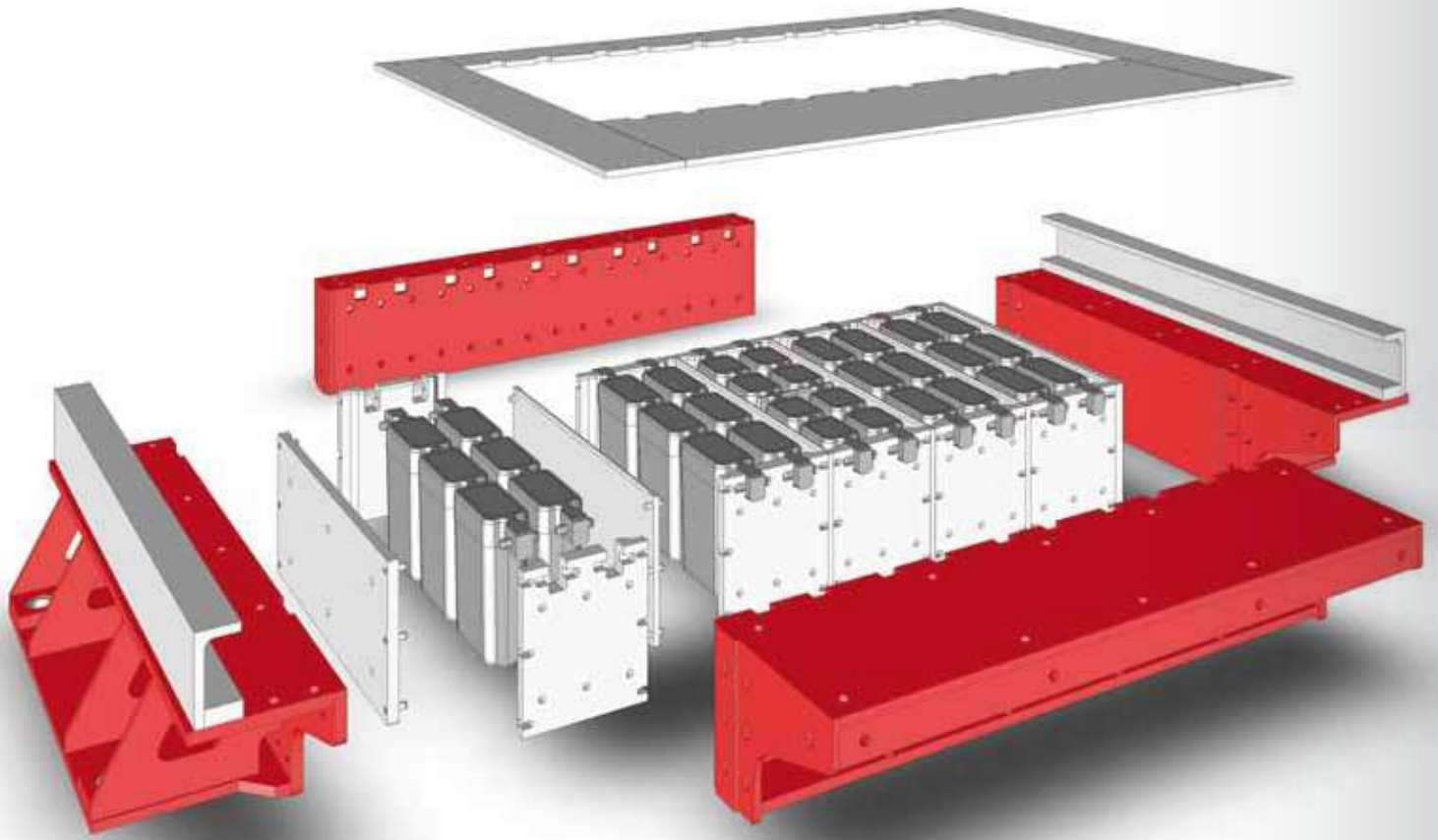

Completely detachable
moulds

Moldes completamente
desmontables

Moldes completamente
desmontáveis

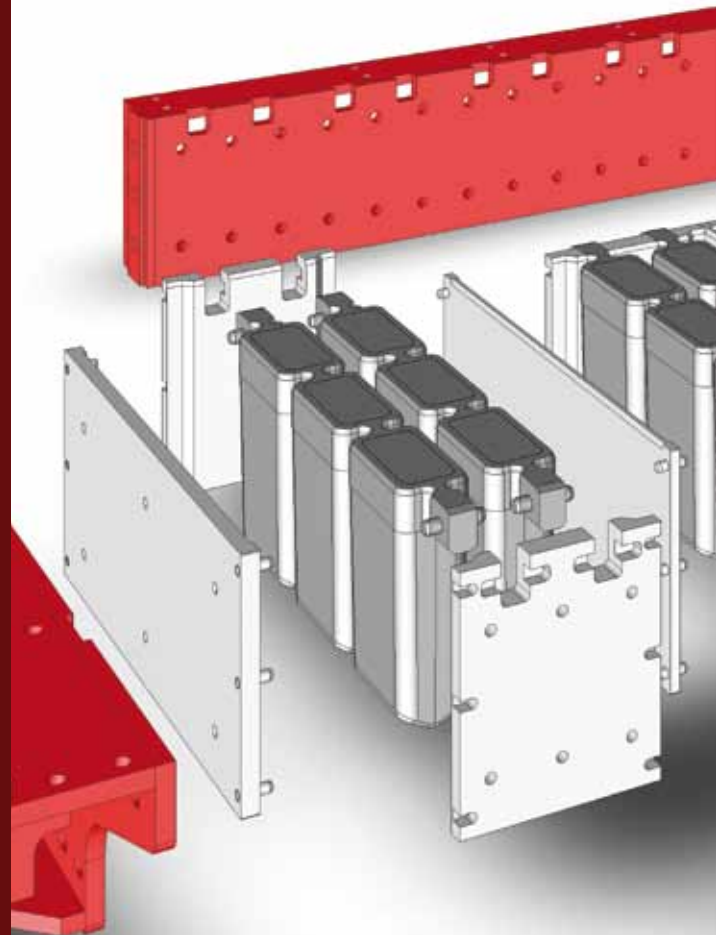

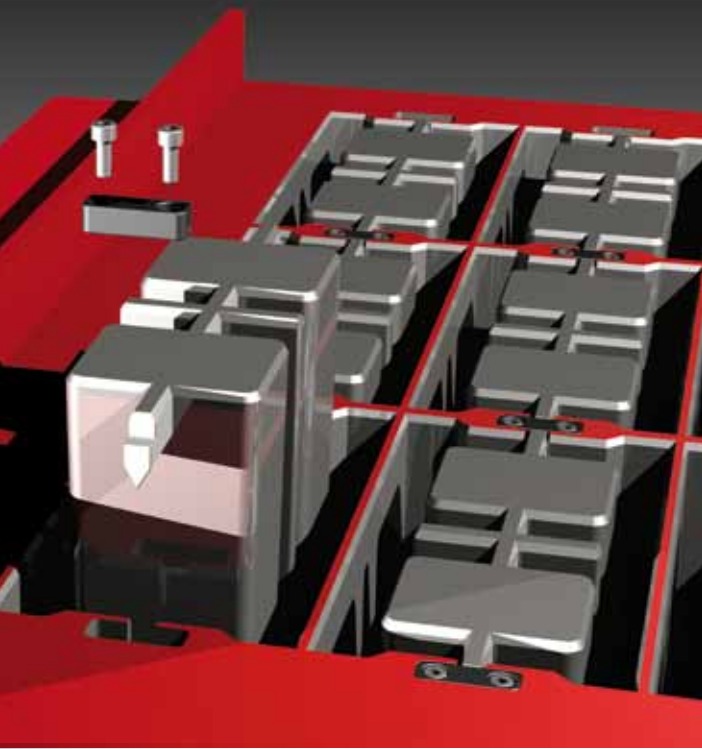

Moulds with
detachable cores

Moldes con núcleos
desmontables

Moldes com almas
desmontáveis

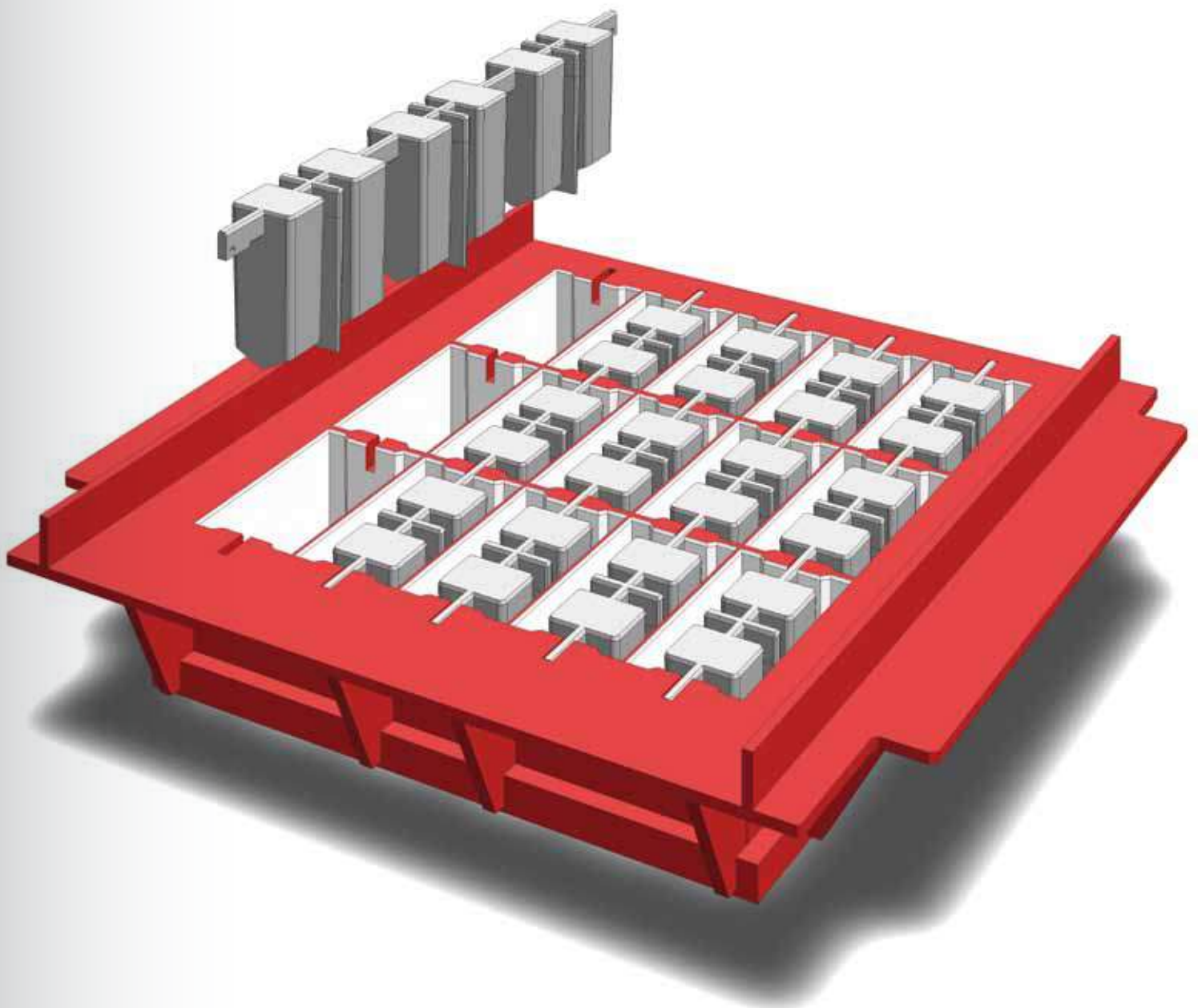



**PEGASO
STAMPI**

Pegaso Stampi S.r.l.

Via Tevere, 1/2

53036 Poggibonsi (SI)

ITALY

Tel. +39 0577 992635

Fax +39 0577 985866

info@pegasostampi.it

www.pegasostampi.com

